



**OUR
POS
RANGE**

BRAND NEW
PHOENIX POS CHECKOUT RANGE

SOLUTIONS FOR ANY APPLICATION



Phoenix metal checkouts, durable, reliable and affordable designed in Australia for the local market, stainless steel tops, aluminum extrusion to withstand heavy trolley traffic, adjustable legs, internal storage and external shelving options for impulse sales.

- A** Mobile POS unit, for peak seasonal trading conditions.
- B** Express checkout universal, can be LH or RH
- C** Self Pack Single Checkout LH or RH available also in tandem formations 2.6 or 3m
- D** Self Pack Single Checkout LH or RH available also in tandem formations 2.6 or 3m

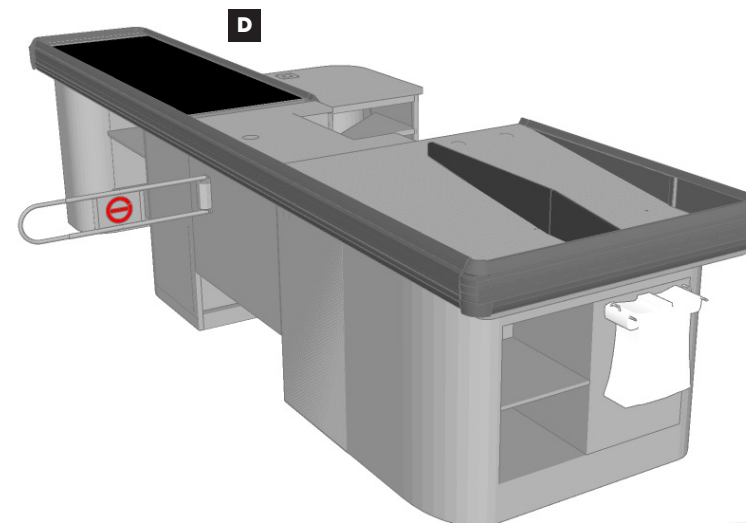
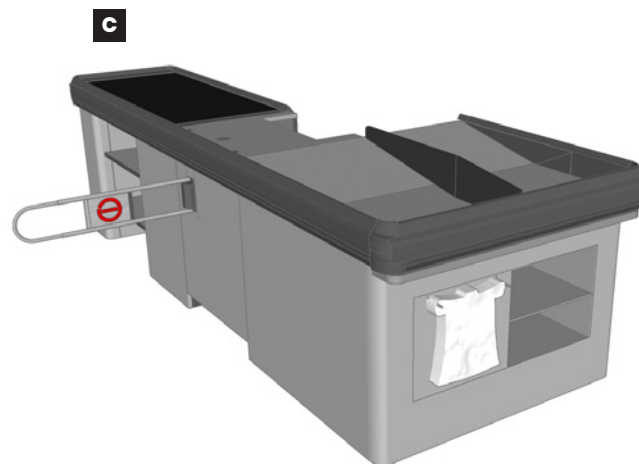
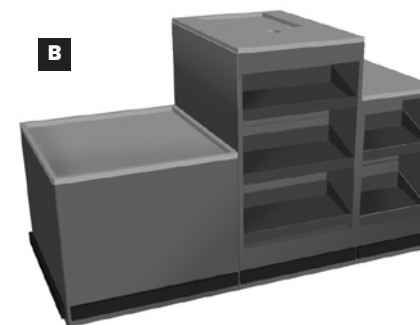
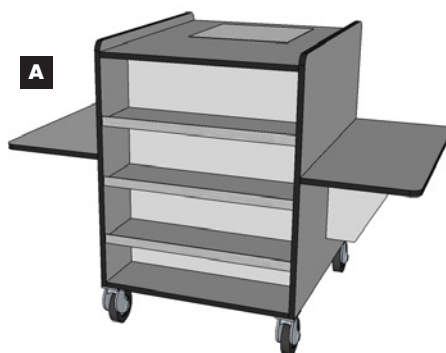

DURABLE METAL WITH TIMBER HIGHLIGHTS

- D** Express Checkout 1550 with conveyor LH/RH available.
- E** Single checkout with conveyor 3m LH/RH
- F** Express Checkout 1500 LH/RH
- G** Tandem 3m x 2.5 checkout with conveyor and dual bag pack

